

# Autonics PULSE METER MP5S/Y/W SERIES INSTRUCTION MANUAL



Thank you for choosing our Autonics product. Please read the following safety considerations before use.

## Safety Considerations

- Please observe all safety considerations for safe and proper product operation to avoid hazards.
- Safety considerations are categorized as follows.
  - Warning** Failure to follow these instructions may result in serious injury or death.
  - Caution** Failure to follow these instructions may result in personal injury or product damage.
- The symbols used on the product and instruction manual represent the following
  - symbol represents caution due to special circumstances in which hazards may occur.

## Warning

- Fail-safe device must be installed when using the unit with machinery that may cause serious injury or substantial economic loss. (e.g. nuclear power control, medical equipment, ships, vehicles, railways, aircraft, combustion apparatus, safety equipment, crime/disaster prevention devices, etc.) Failure to follow this instruction may result in personal injury, fire, or economic loss.
- The unit must be installed on a device panel before use. Failure to follow this instruction may result in electric shock.
- Do not connect, repair, or inspect the unit while connected to a power source. Failure to follow this instruction may result in electric shock.
- Do not disassemble or modify the unit. Please contact us if necessary. Failure to follow this instruction may result in electric shock or fire.
- Check the terminal numbers before connecting the power source and measurement input. Failure to follow this instruction may result in fire.

## Caution

- Do not use the unit outdoors. Failure to follow this instruction may result in electric shock or shortening the life cycle of the unit.
- When connecting the power input or measuring input, make sure to tighten the terminal screw bolt above 0.74N·m to 0.90N·m. Contact failure may result in fire.
- Use the unit within the rated specifications. Failure to follow this instruction may result in electric shock or shortening the life cycle of the unit.
- Do not use loads beyond the rated switching capacity of the relay contact. Failure to follow this instruction may result in insulation failure, contact failure, contact bonding, relay damage, or fire.
- Do not use water or oil-based detergent when cleaning the unit. Use dry cloth to clean the unit. Failure to follow these instructions may result in electric shock or fire.
- Do not use the unit where flammable or explosive gas, humidity, direct sunlight, radiant heat, vibration, and impact may be present. Failure to follow this instruction may result in fire or explosion.
- Keep dust and wire residue from flowing into the unit. Failure may result in fire or product malfunction.
- Check the polarity of the measurement input contact before wiring the unit. Failure to follow this instruction may result in fire or explosion.

## Ordering Information

MP	5	Y	-	4	N
Item	MP	Pulse meter			
Digits	5	99999 (5 Digit)			
Size	S	DIN W48×H48mm			
	Y	DIN W72×H36mm			
	W	DIN W96×H48mm			
Power supply	2	24VAC 50/60Hz, 24-48VDC			
	4	100-240VAC 50/60Hz			
Output	S	Main output (Comparative value output)			
	N	Indicator			
	1	NPN open collector quintuple output			
	2	PNP open collector quintuple output			
	3	Indicator BCD Dynamic			
	4	Indicator PV transmission (current output)			
	5	Indicator RS485 communication			
	6	Relay triple output (H, GO, L)			
	A	Relay quintuple output (HH, H, GO, L, LL)			
	1	Relay triple output (H, GO, L)			
	2	NPN open collector quintuple output BCD Dynamic			
	4	NPN open collector quintuple output PV transmission (current output)			
	5	PNP open collector quintuple output PV transmission (current output)			
	8	NPN open collector quintuple output RS485 communication			
	9	PNP open collector quintuple output RS485 communication			

The above specifications are subject to change and some models may be discontinued without notice.

## Specifications

Series	MP5S	MP5Y	MP5W
Display method	7 Segment LED(Zero Blanking method)		
Character size	W4×H8mm	W7×H14mm	
Display range	-19999 to 99999		
Power supply	AC voltage 100-240VAC 50/60Hz AC/DC voltage 24VAC 50/60Hz, 24-48VDC		
Power consumption	AC voltage Max. 7.5VA (100-240VAC 50/60Hz) AC/DC voltage Max. 6.0VA (24VAC 50/60Hz), Max. 4.5W (24-48VDC)	Max. 9.0VA (100-240VAC 50/60Hz) Max. 7.0VA (24VAC 50/60Hz), Max. 6.2W (24-48VDC)	Max. 10.0VA (100-240VAC 50/60Hz) Max. 7.5VA (24VAC 50/60Hz), Max. 7.0W (24-48VDC)
Permissible voltage range	90 to 110% of rated voltage		
External sensor power	12VDC±10%, 80mA		
Sub power supply	24VDC 30mA		
Input frequency	Solid state input: max. 50kHz (pulse width: min. 10μs) Contact input: max. 45Hz (pulse width: min. 11ms)		
Input method	[Voltage input] High: 4.5-24VDC, Low: 0-1.0VDC, Input impedance: 2.4kΩ [No-voltage input] Short-circuit impedance: max. 80Ω, Residual voltage: min. 1V, Open-circuit impedance: min. 100kΩ		
Measurement range	Mode F1, F2, F7, F8, F9, F10 : 0.0005Hz to 50kHz Mode F3, F4, F5, F6 : 0.01 to max. of each time range Mode F11, F12, F13, F16 : 0 to 99999 Mode F14, F15 : -19999 to 99999		
Measurement accuracy(23±5°C)	Mode F1, F2, F7, F8, F9, F10: F.S.±0.05%rdg±1digit Mode F3, F4, F5, F6: F.S.±0.01%rdg±1digit		
Display cycle	OFF (for F2, F16), 0.05, 0.5, 1, 2, 4, 8 sec. (same as update output cycle)		
Operation mode	Frequency/Revolutions/Speed (F1), Passing speed (F2), Cycle (F3), Passing time (F4), Time interval (F5), Time differential (F6), Absolute ratio (F7), Error ratio (F8), Density (F9), Error (F10), Length measurement 1 (F11), Interval (F12), Accumulation (F13), Addition/Subtraction-individual input (F14), Addition/Subtraction-phase difference input (F15), Length measurement 2 (F16)		
Prescale function	Direct input method (0.0001×10 <sup>9</sup> to 9.9999×10 <sup>9</sup> )		
Hysteresis	0 to 9999		
Output	Main Relay(triple) Relay(quintuple) NPN/PNP open collector quintuple BCD Dynamic	Sub Analog Communication	250VAC 3A resistive load 250VAC 3A resistive load Max. 30VDC 30mA Max. 30VDC 30mA DC4-20mA/DC0-20mA max. load 500Ω RS485 communication output (Modbus RTU method)
Memory retention	Non-volatile memory (number of inputs: 100,000 operations)		
Insulation resistance	Min. 100MΩ (at 500VDC megger)		
Dielectric strength	2,000VAC 60Hz for 1min.		
Noise resistance	±2kV the square wave noise (pulse width: 1μs) by the noise simulator		
Vibration	Mechanical Malfunction	0.75mm amplitude at frequency of 10 to 55Hz in each X, Y, Z direction for 1 hours 0.5mm amplitude at frequency of 10 to 55Hz in each X, Y, Z direction for 10 minutes	
Shock	Mechanical Malfunction	300m/s <sup>2</sup> (approx. 30G) in each X, Y, Z direction for 3 times 100m/s <sup>2</sup> (approx. 30G) in each X, Y, Z direction for 3 times	
Relay life cycle	Mechanical Electrical	Min. 10,000,000 operations Min. 100,000 operations (250VAC 3A resistive load)	
Environment	Ambient temp. Ambient humi.	-10 to 50°C, storage: -20 to 60°C 35 to 85%RH, storage: 35 to 85%RH	
Approval	CE, UL, IEC		
Weight	Approx. 191g (approx. 132g)	Approx. 230g (approx. 140g)	Approx. 334g (approx. 210g)

※1: Setting range will vary depending on the decimal point.  
※2: The weight includes packaging. The weight in parentheses is for unit only.  
※Environment resistance is rated at no freezing or condensation.

## Dimensions

※Side dimensions of MP5Y/W differ by output type.

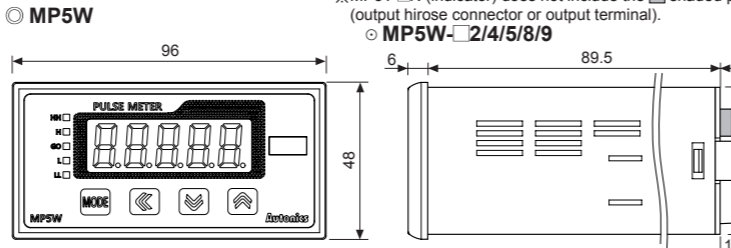
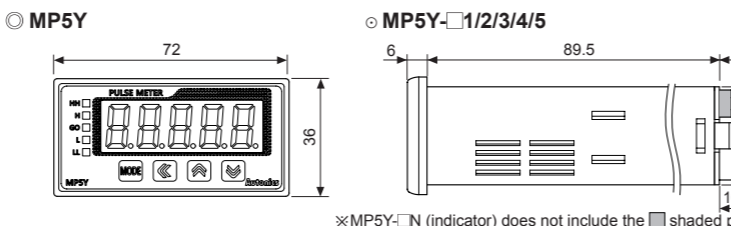
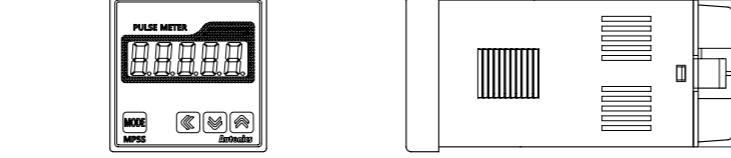

## Panel Cut-out Dimensions

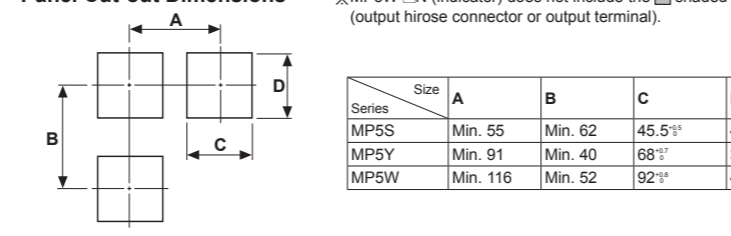

## Connections

### MP5Y Series

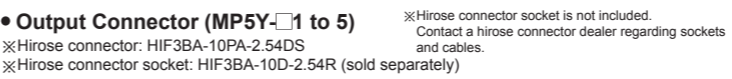
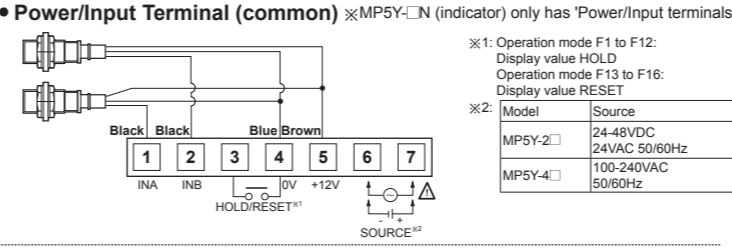

### MP5Y-1 (NPN open collector output)

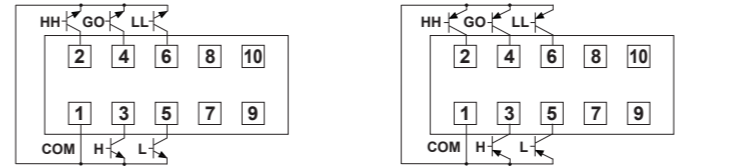

### MP5Y-3 (BCD dynamic output)

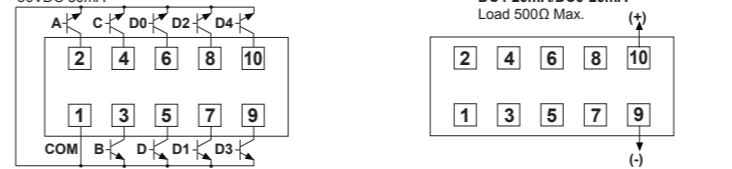

※Autonics display unit (DS Series) is recommended for stable minus (-) sign display.

### Output Terminal (MP5Y-6)

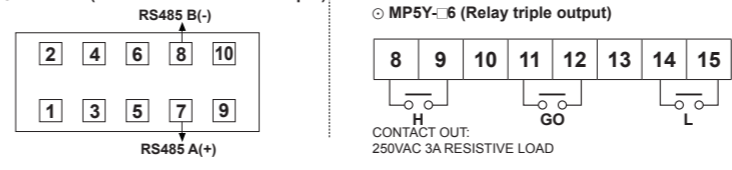

### Bracket

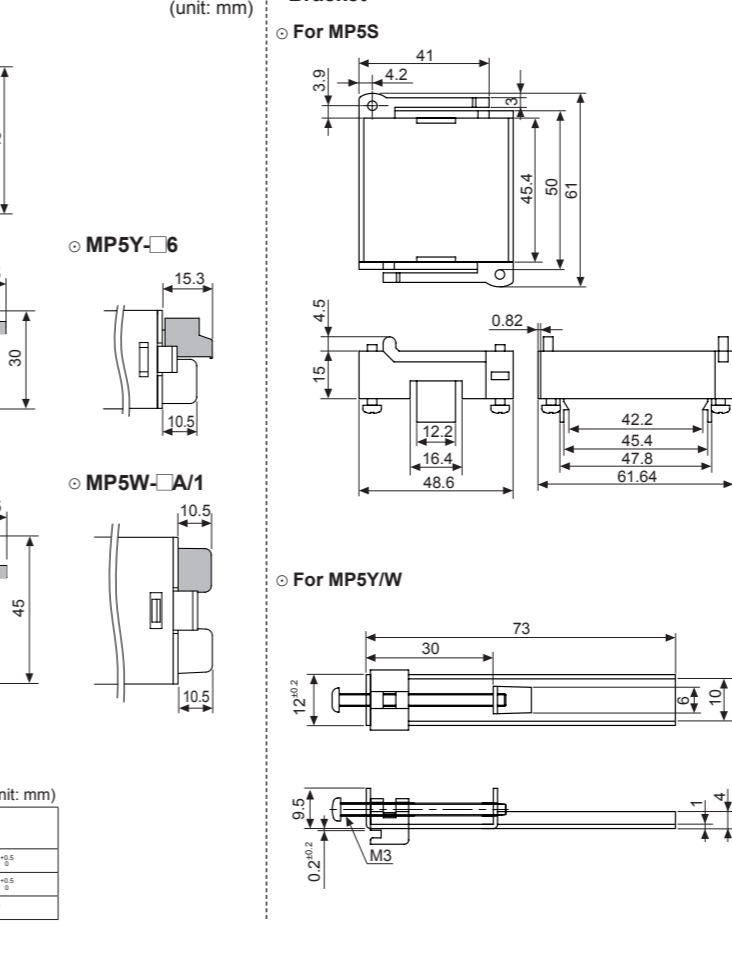

## MP5S Series

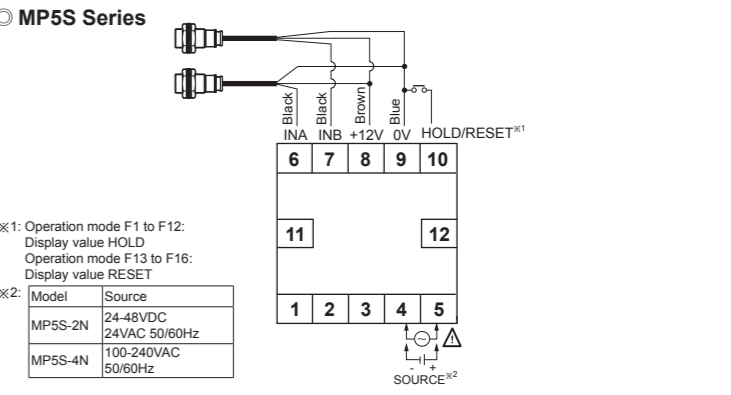

## MP5W Series

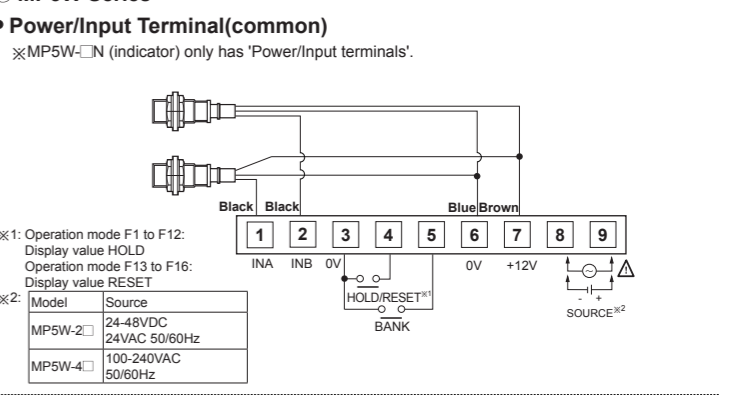

### Output Terminal (MP5W-1/2)

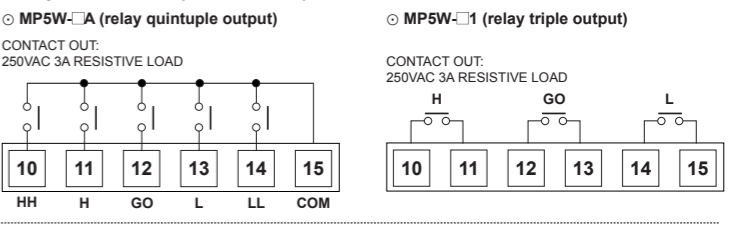

### Output Connector (MP5W-2/4/5/8/9)

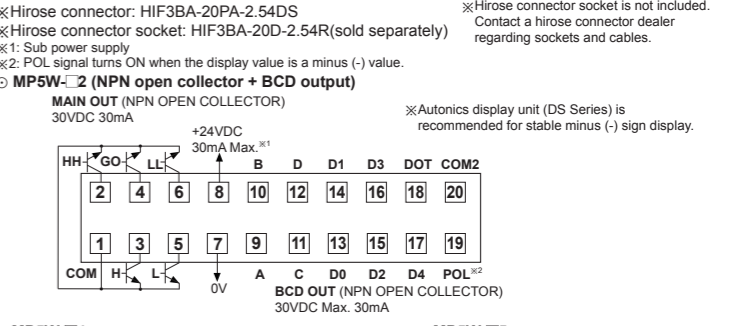

### MP5W-4 (NPN open collector + PV transmission output)

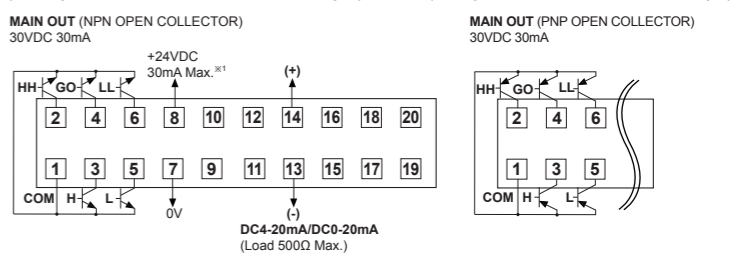

### MP5W-8 (NPN open collector + RS485 com. output)

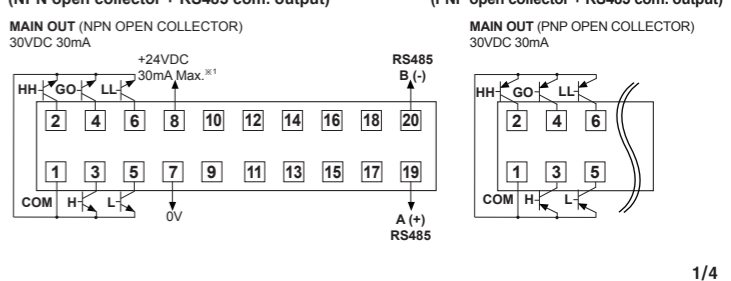

## Input/Output Specifications

### 1. Input Specifications

- (1) Solid state input
- Input frequency: max. 50kHz (standard duty ratio of input signal: 1:1, ON/OFF pulse width: Min. 10μs of each)
  - Input voltage level: ON voltage → 4.5-24V, OFF voltage → 0-1.0V
- (2) Contact input
- Input frequency: Max. 45Hz (when each ON/OFF pulse width is over 11ms)
  - Contact specifications: 12VDC, stable switching of load current as small as 5mA

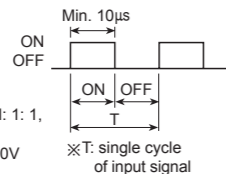

### 2. Input type

- MP5 allows selection between NPN input (solid state/contact) or PNP input (solid state/contact).
- (1) NPN input type (2) PNP input type

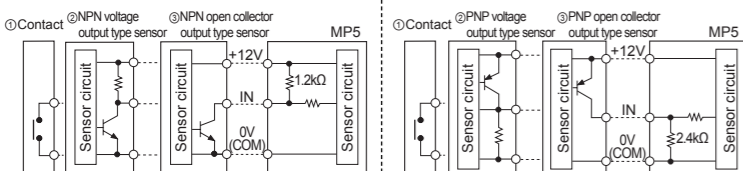

### 3. Output Specifications

1. Relay output
- Output: Comparative or alarm output (refer to "Output mode")
  - Output type: Relay
  - Contact capacity: 250VAC 3A resistive load
  - Life cycle: [Mechanical] min. 10,000,000 operations (switching frequency 180 operations/min.) [Electrical] min. 100,000 operations (3A 250VAC, 30VDC resistive load) (switching frequency 20 operations/min.)
2. Transistor output
- Output: Comparative output or alarm output (refer to "Output mode")
  - Output type: NPN/PNP open collector
  - Rated load voltage: 30VDC
  - Max. load current: 30mA

### 4. BCD dynamic output (negative logic)

- Output: present value
- Output signal: BCD data (A, B, C, D, DOT) ← A: lowest bit, DOT: highest bit
- Output type: NPN open collector
- Rated load voltage: 30VDC
- Max. load current: 30mA
- Dynamic COM cycle (T) = 39ms
- E.g.) To display value = 125.89 by BCD dynamic output

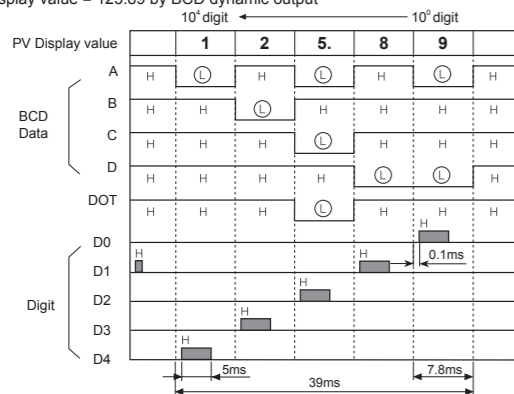

### 5. PV transmission output

- Application: transmit measured value
- Function: transmit measured value within setting range of high-limit output [F5-H] to low-limit output [F5-L] after conversion into DC4-20mA or DC0-20mA current.
- Output range of high/low-limit
- High-limit [F5-H] range: From min. value to max. value within measurement range
- Low-limit [F5-L] range: From min. value to max. value within measurement range ([F5-H] ≥ [F5-L] + 1)

#### (1) DC4-20mA transmission output

- Transmit measured value within setting range of high-limit output [F5-H] to low-limit output [F5-L] after conversion into DC4-20mA current.
- Resistive load: Max. 500Ω
- Resolution: 8000 divisions

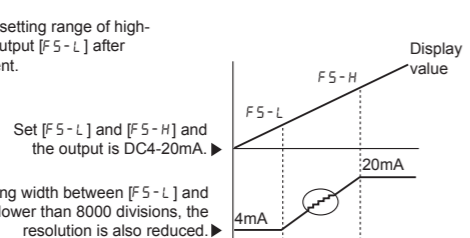

#### (2) DC0-20mA transmission output

- Transmit measured value within setting range of high-limit output [F5-H] to low-limit output [F5-L] after conversion into DC0-20mA current.
- Resistive load: Max. 500Ω
- Resolution: 10,000 divisions

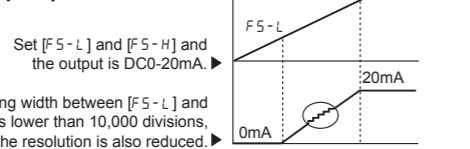

### 6. RS485 communication output

Communication protocol	Modbus RTU	Communication Speed	2400, 4800, 9600 (default), 19200, 38400 bps
Connection method	RS485	Start Bit	1-bit fixed
Max. connections	31 units (address: 1 to 99)	Data Bit	8-bit fixed
Communication method	2-wire half duplex	Parity Bit	None (default), Even, Odd
Synchronization method	Asynchronous	Stop Bit	1, 2-bit (default)
Communication distance	Within 800m	Communication response time	5 to 99ms (default: 20ms)

※For more information about RS485 communication output specifications, refer to "RS485 communication output".

## Unit Description

### MP5S

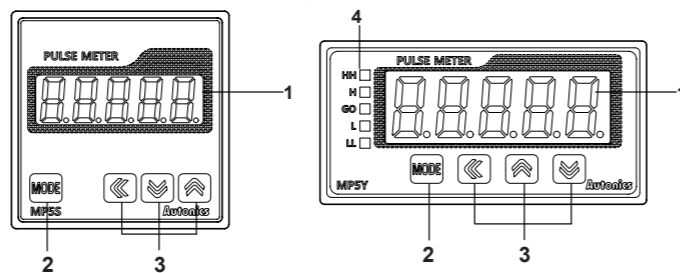

### MP5Y

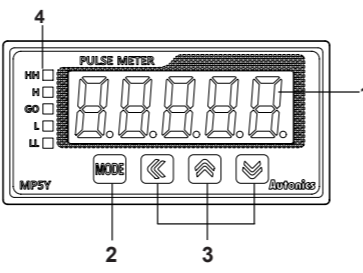

### MP5W

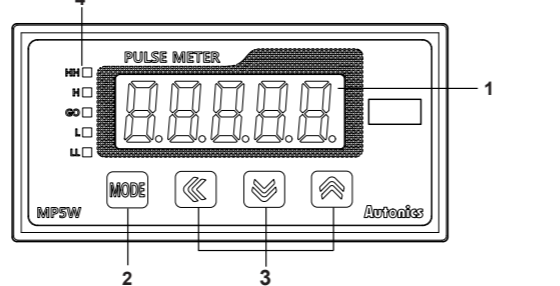

#### 1: Display component

Displays current value in RUN mode. Alternately displays setting parameters and corresponding value in SETTING mode.

#### 2: MODE key

In RUN mode, press the key once to check max./min. value. In RUN mode, hold the key for over 2 sec. to enter parameter groups.

#### 3: [Left], [Up], [Down] key

Select parameter groups, and select or setting values in the corresponding parameters.

#### 4: Output status indicator

## Parameter Groups

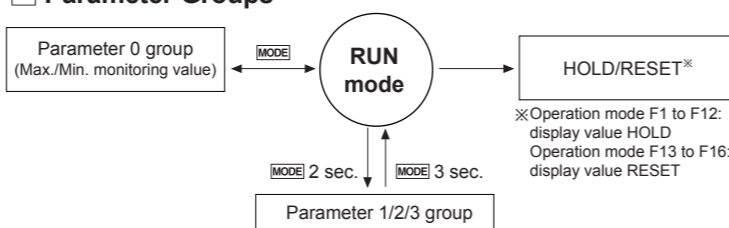

- Press the [Left], [Up], [Down] keys to select or set the desired value.
- Press the MODE key once after changing the setting value, to save the setting value and move to the next parameter.
- Hold the MODE key for 1.5 sec. at any parameters to return to the select parameter group mode.
- Hold the MODE key for 3 sec. to save the setting value and return to RUN mode after changing the setting value.
- If there is no key input for 60 sec. while setting the parameters, the new settings are ignored, and the unit will return to RUN mode with previous settings.
- The dotted line parameters may not appear depending on output specifications or other parameter settings. Please refer to "Operation mode by parameter group".
- 1: Each parameter and corresponding setting value will flash alternately every 0.5 sec.

### Parameter 0 Group

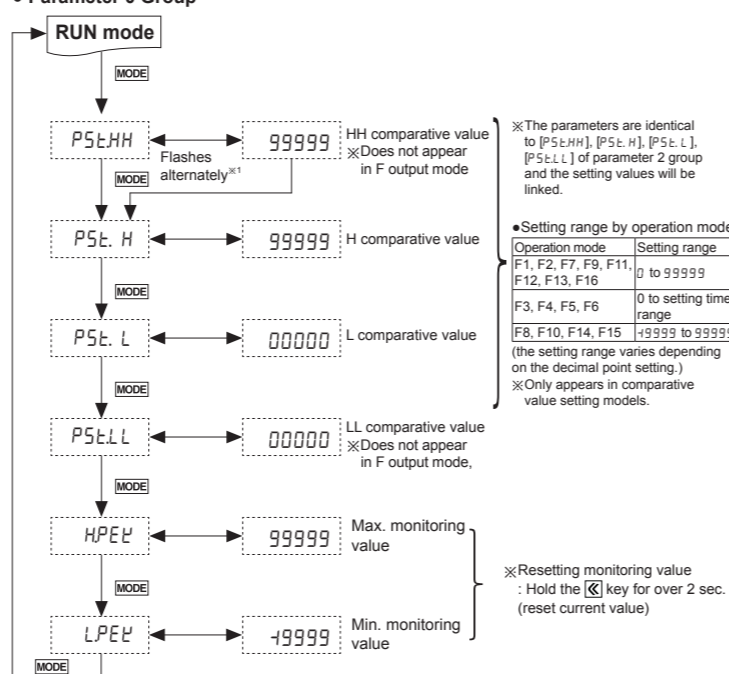

### Parameter 1 Group

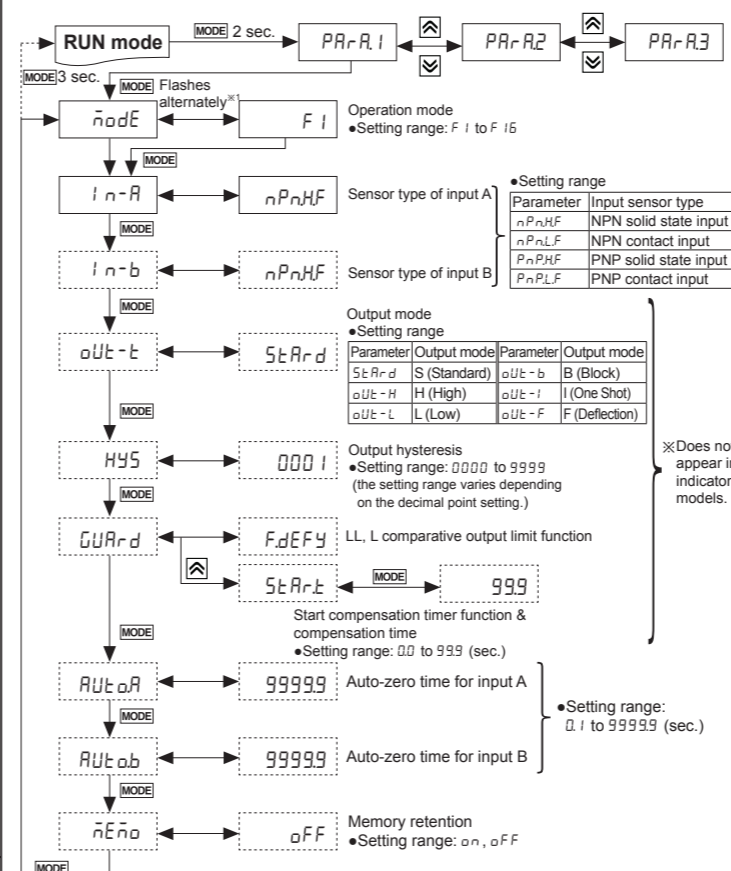

### Parameter 2 Group

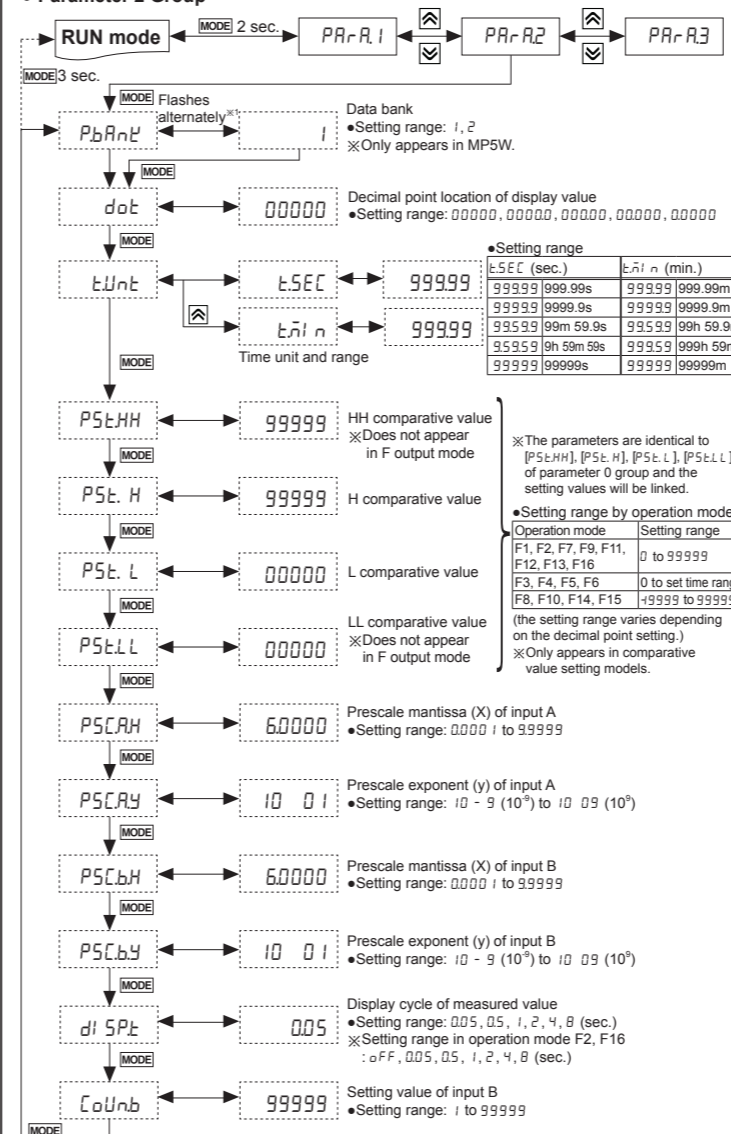

### Parameter 3 Group

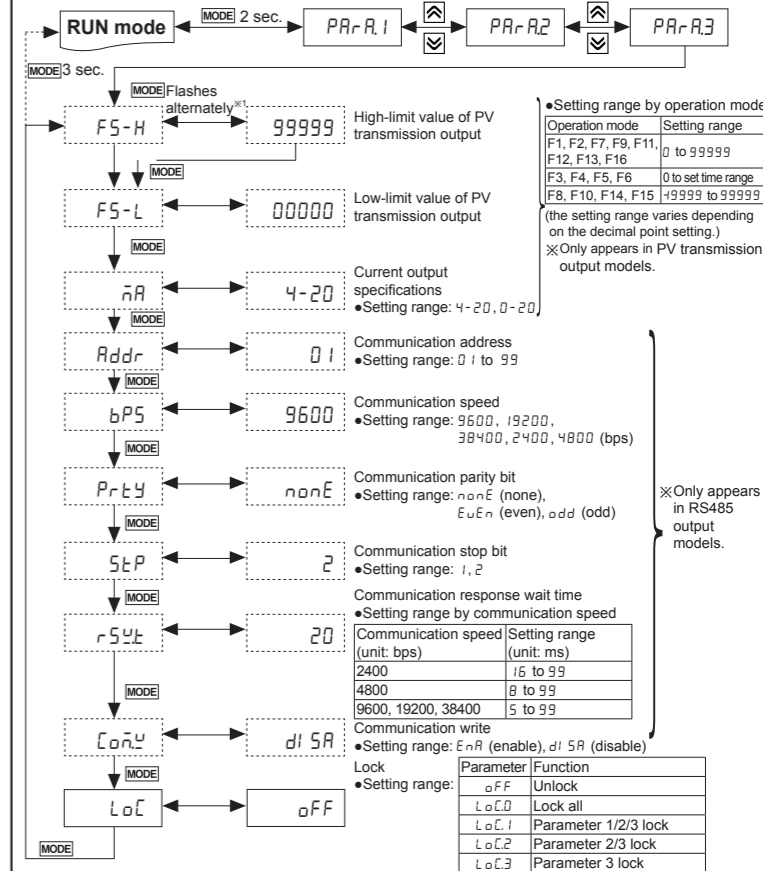

## Operation Mode By Parameter Groups

Parameter	Operation mode	F1	F2	F3	F4	F5	F6	F7	F8	F9	F10	F11	F12	F13	F14	F15	F16	
0 group	PSt.HH <sup>※1</sup>																	
	PSt.H <sup>※2</sup>																	
	PSt.L <sup>※2</sup>																	
	PSt.LL <sup>※1</sup>																	
1 group	HPEL														X		X	
	LPEL														X		X	
	nAdE																	
	In-A	X		X	X	X												
	In-B		X															
	oUt-t														X			
	HYS		X	X	X	X									X	X	X	
	GUAR-d														X	X	X	
	AUt-a		X	X	X	X	X								X	X	X	
	AUt-ab	X	X	X	X	X	X								X	X	X	
2 group	nEn	X	X	X	X	X	X	X	X	X	X	X	X	X	X	X		
	PbAnE																	
	dot			X	X	X	X											
	tUnE	X	X						X	X	X	X	X	X	X	X	X	
	PSt.HH <sup>※1</sup>																	
	PSt.H <sup>※2</sup>																	
	PSt.L <sup>※2</sup>																	
	PSt.LL <sup>※1</sup>																	
	PSt.AH			X		X	X											
	PSt.AY			X		X	X											
3 group	PSt.bH	X	X	X	X	X	X											
	PSt.bY	X	X	X	X	X	X											
	diSPt			X	X	X	X								X	X	X	
	CoUnb	X	X	X	X	X	X	X	X	X	X	X	X	X	X	X	X	
	F5-H																	
	F5-L																	

- ※1: Only appears in only for quintuple output models.
- ※2: Only appears in triple, quintuple output models.
- ※3: (○) Only nPNHF or PnPHF setting are available for input B sensor type.
- ※4: The settings for In-B and In-A are applied.
- ※5: (●) F output mode [oUt-F] cannot be set.
- ※6: (■) setting range: oFF, 0.05, 0.5, 1, 2, 4, 8

Monitoring delay function by output mode

Output mode	S mode	H mode	L mode	B mode	I mode	F mode
Comparative output limit						
Start compensation timer						



### Operation Modes

- Select operation mode from operation mode [0~dE] of parameter 1 group.
- MP5 has 16 operation modes.

#### F1 Mode: Frequency/Revolutions/Speed

Measures the frequency of input A and displays the calculated frequency, revolutions, and speed.

- 1) Frequency(Hz) =  $f \times \alpha$  ( $\alpha = 1[\text{sec}]$ )
  - 2) Revolutions(rpm) =  $f \times \alpha$  ( $\alpha = 60[\text{sec}]$ )
  - 3) Speed(m/min) =  $f \times \alpha$  ( $\alpha = 60L[\text{sec}]$ )
- ※ L: travel distance of conveyor belt of 1 cycle[m]  
 ※  $\alpha$ : prescale value  
 For multiple objects,  $\alpha = \frac{60L}{N}$

#### Display value and display unit

Display value	Display unit	$\alpha$ (prescale value)
Frequency	Hz	1
	kHz	0.001
Revolutions	rps	1
	rpm(default)	60
Speed	mm/sec	1,000L
	cm/sec	100L
	m/sec	1L
	m/min	60L
	km/hour	3.6L

#### Timing chart

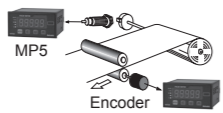
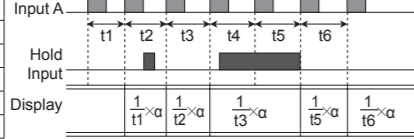

#### F2 Mode: Passing Speed

Displays the passing speed between input A ON and input B ON.

Passing speed(V) =  $f \times \alpha$  ( $\alpha = L[\text{m}]$ )

- ※ f: reciprocal of time [sec.] between input A(sensor) ON and input B(sensor) ON.  
 L: distance between input A(sensor) and input B(sensor) [m]  
 $\alpha$ : prescale value

#### Display value and display unit

Display value	Display unit	$\alpha$ (prescale value)
Passing speed	mm/sec	1,000L
	cm/sec	100L
(default)	m/sec	1L
	m/min	60L
	km/hour	3.6L

#### Timing chart

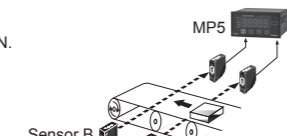
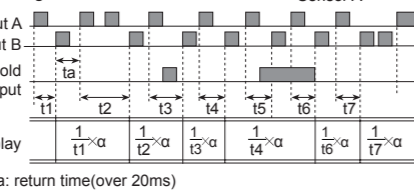

#### F3 Mode: Cycle

Displays the measured time from input A ON to the next ON.

Cycle(T) = t

- ※ t: measurement time[sec]  
 ※ Display value and display unit [t:Unit] of parameter 2)

Display value	Display unit	Min.
Cycle	Sec.	999.99s
	(default)	999.99m
	9999.9s	9999.9m
	99m 59.9s	99h 59.9m
	9h 59m 59s	999h 59m
99999s	99999m	

#### Timing chart

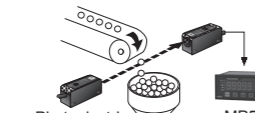
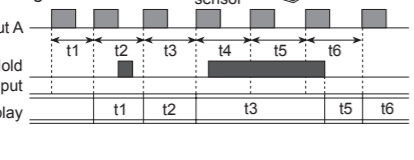

#### F4 Mode: Passing Time

Measure the time from input A ON to the next ON, and displays the passing time of the arbitrary distance.

Passing time[sec] =  $t \times \alpha$   
 ( $\alpha = \frac{L[\text{m}]}{\text{Distance advanced in 1 pulse cycle}[\text{m}]}$ )

- ※ t: measured time[sec], L: arbitrary distance[m]  
 $\alpha$ : prescale value

#### Display value and display unit [t:Unit] of parameter 2)

Display value	Display unit	Min.
Passing time	Sec.	999.99s
	(default)	999.99m
	9999.9s	9999.9m
	99m 59.9s	99h 59.9m
	9h 59m 59s	999h 59m
99999s	99999m	

#### Timing chart

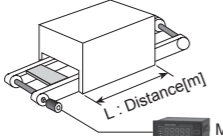
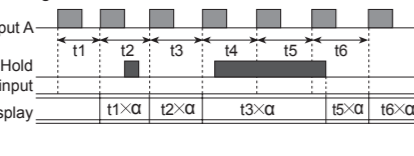

#### F5 Mode: Time Interval

Displays measured time of input A ON.

Time interval(T) = t

- ※ t: measured time of input A ON [sec]  
 ※ Display value and display unit [t:Unit] of parameter 2)

Display value	Display unit	Min.
Time interval	SEC	999.99s
	(default)	999.99m
	9999.9s	9999.9m
	99m 59.9s	99h 59.9m
	9h 59m 59s	999h 59m
99999s	99999m	

#### Timing chart

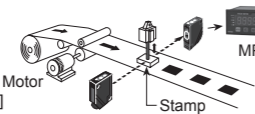
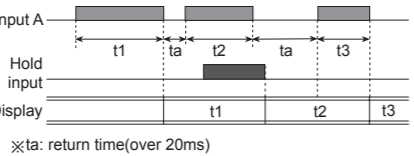

#### F6 Mode: Time Differential

Displays measured time from Input A ON to Input B ON.

Time difference(T) = (t<sub>a</sub> to t<sub>b</sub>)

- ※ (t<sub>a</sub> to t<sub>b</sub>): measured time from input A ON to input B ON [sec]  
 ※ Display value and display unit [t:Unit] of parameter 2)

Display value	Display unit	Min.
Time differential	Sec.	999.99s
	(default)	999.99m
	9999.9s	9999.9m
	99m 59.9s	99h 59.9m
	9h 59m 59s	999h 59m
99999s	99999m	

#### Timing chart

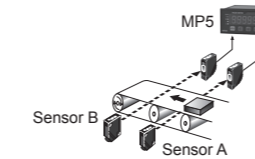
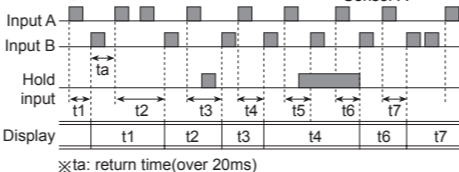

#### F7 Mode: Absolute Ratio

Measures and displays relative speed, amount, speed, etc. of input B against input A in percentage(%).

Absolute ratio = (Input B / Input A) × 100%

Absolute ratio =  $\frac{\text{Frequency of input B}[\text{Hz}] \times \text{Ba}}{\text{Frequency of input A}[\text{Hz}] \times \text{Aa}} \times 100[\%]$

- ※ Aa: prescale value of input A, Ba: prescale value of input B

#### Display value and display unit

Display value	Display unit
Absolute ratio	%

#### Timing chart

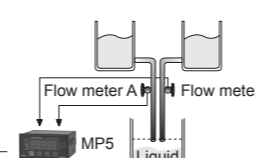
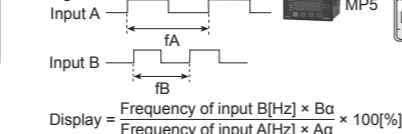

※ Hold: When the hold signal turns ON, the display value is maintained until the display cycle turns to hold OFF.

#### F8 Mode: Error Ratio

Measures and displays the relative rate of input B against the reference value of input A in percentage(%).

Error ratio =  $\frac{\text{Input B} - \text{Input A}}{\text{Input A}} \times 100[\%]$   
 Error ratio =  $\frac{(\text{Frequency of input B}[\text{Hz}] \times \text{Ba}) - (\text{Frequency of input A}[\text{Hz}] \times \text{Aa})}{\text{Frequency of input A}[\text{Hz}] \times \text{Aa}} \times 100[\%]$

- ※ Aa: prescale value of input A, Ba: prescale value of input B

#### Display value and display unit

Display value	Display unit
Error ratio	%

#### Timing chart

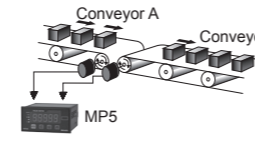
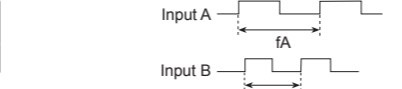

※ Hold: When the hold signal turns ON, the display value is maintained until the display cycle turns to hold OFF.

#### F9 Mode: Density

Measures and displays the density ratio (%) of input B against the total sum of input A and input B.

Density =  $\frac{\text{Input B}}{\text{Input A} + \text{Input B}} \times 100[\%]$   
 Density =  $\frac{\text{Frequency of input B}[\text{Hz}] \times \text{Ba}}{(\text{Frequency of input A}[\text{Hz}] \times \text{Aa}) + (\text{Frequency of input B}[\text{Hz}] \times \text{Ba})} \times 100[\%]$

- ※ Aa: prescale value of input A, Ba: prescale value of input B

#### Display value and display unit

Display value	Display unit
Density	%

#### Timing chart

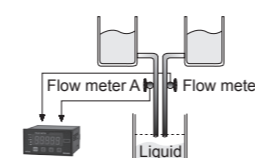
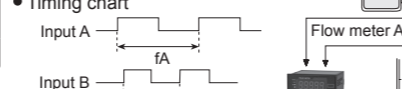

※ Hold: When the hold signal turns ON, the display value is maintained until the display cycle turns to hold OFF.

#### F10 Mode: Error

Measures and displays the error of input B against reference value of input A.

Error = Input B - Input A  
 Error = (Frequency of input B[Hz] × Ba) - (Frequency of input A[Hz] × Aa)

- ※ Aa: prescale value of input A, Ba: prescale value of input B

#### Display value and display unit

Display value	Display unit
Error	END User setting

#### Timing chart

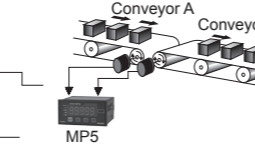
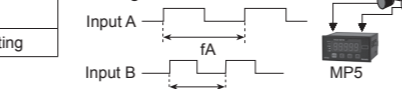

※ Hold: When the hold signal turns ON, the display value is maintained until the display cycle turns to hold OFF.

#### F11 Mode: Length Measurement 1

Measure and display the number of input A pulses during input B ON.

Length measurement = P ×  $\alpha$

- ※ P: number of input A pulses,  $\alpha$ : prescale value

#### Display value and display unit

Display value	Display unit
Length measurement	Quantity (default)
	mm
	cm
	m

#### Timing chart

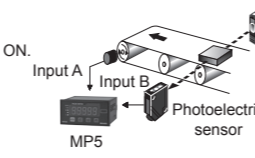
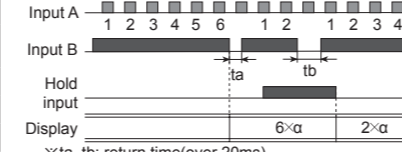

※ t<sub>a</sub>, t<sub>b</sub>: return time(over 20ms)

#### F12 Mode: Interval

Measures and displays the number of input A pulses from input B ON to the next ON.

Interval = P ×  $\alpha$

- ※ P: number of input A pulses,  $\alpha$ : prescale value

#### Display value and display unit

Display value	Display unit
Interval	Quantity (default)
	mm
	cm
	m

#### Timing chart

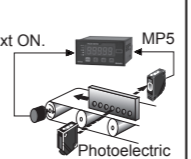
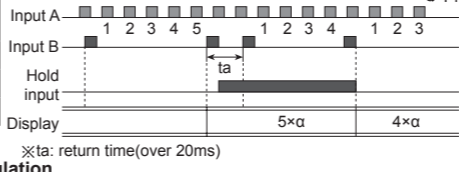

#### F13 Mode: Accumulation

Measures and displays the counted value of input A pulses.

Accumulation = P ×  $\alpha$

- ※ P: number of input A pulses,  $\alpha$ : prescale value

#### Operation

① Counts the number of input A pulses

② Input B is an enable input signal.

During ON, the quantity and display value of input A will be held, and during OFF input A will be re-counted.

③ When RESET input is ON, the integrated counted value will be reset to "0"

#### Display value and display unit

Display value	Display unit
Accumulation	Quantity

#### Timing chart

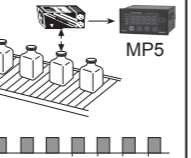
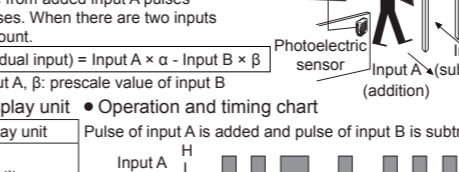

#### F14 Mode: Addition/Subtraction-Individual Input

Displays the counted value from added input A pulses and subtracted input B pulses.

When there are two inputs simultaneously, it will not count.

Addition/Subtraction(individual input) = Input A ×  $\alpha$  - Input B ×  $\beta$

- ※  $\alpha$ : prescale value of input A,  $\beta$ : prescale value of input B

#### Display value and display unit

Display value	Display unit
Addition/Subtraction (individual input)	Quantity

#### Operation and timing chart

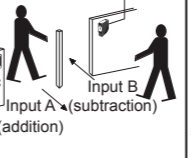
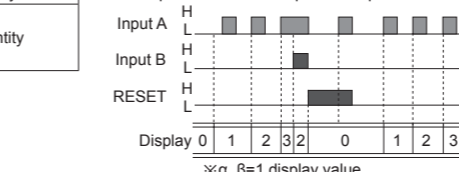

#### F15 Mode: Addition/Subtraction-Phase Difference Input

When input A is Low, counting is added to the low of input B.

When input A is High, counting is subtracted from the high of input B.

Addition/Subtraction(phase difference) = Detects position and speed using A and B phases of encoder outputs as input.

#### Display value and display unit

Display value	Display unit
Addition/Subtraction (phase difference input)	Quantity

#### Timing chart

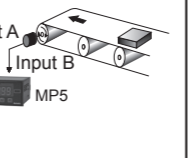
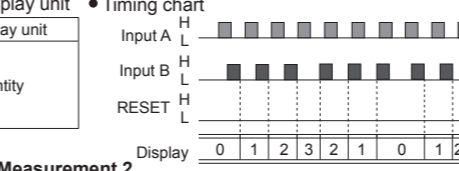

#### F16 Mode: Length Measurement 2

Measures and displays the number of pulses from input A until the value of input B reaches the setting value.

Length measurement 2 = P ×  $\alpha$  (until the setting value of input B)

- ※ P: number of input A pulses,  $\alpha$ : prescale value

#### Display value and display unit

Display value	Display unit
Length measurement 2	Quantity

#### Timing chart (e.g.) setting value of input B=4

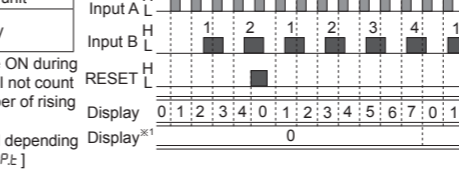

※ If input A and input B are ON during initial power supply, it will not count and only count the number of rising edge.  
 ※ Display value is renewed depending on the display cycle[d: 5P].  
 ※ 1: When the display cycle[d: 5P] setting is OFF, it will maintain the quantity of input A until the value of input B reaches the setting value of input B [c: 0~n].

### Output Modes [0~t - t]

- MP5 Series supports 6 output modes. (There is no output mode in indicator models).
- Requirement for setting comparative value: (B output mode) LL < L < H < HH, (F output mode) L < H, (other output modes) individual output operation regardless of size or order of set comparative values.

#### S(Standard) Output Mode [5tRr-d]

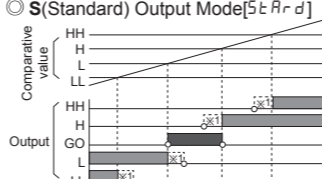

HH output : Display value ≥ Comparative setting value HH  
 H output : Display value ≥ Comparative setting value H  
 L output : Display value ≤ Comparative setting value L  
 LL output : Display value ≤ Comparative setting value LL  
 ※ GO output ON when there are no HH, H, L, LL outputs

#### H(High) Output Mode [0~t - H]

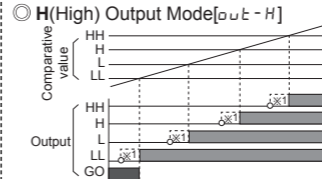

HH output : Display value ≥ Comparative setting value HH  
 H output : Display value ≥ Comparative setting value H  
 L output : Display value ≤ Comparative setting value L  
 LL output : Display value ≤ Comparative setting value LL  
 ※ GO output ON when there are no HH, H, L, LL outputs

#### L(Low) Output Mode [0~t - L]

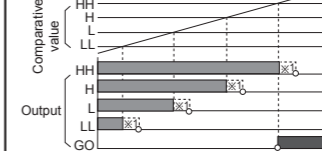

HH output : Display value ≤ Comparative setting value HH  
 H output : Display value ≤ Comparative setting value H  
 L output : Display value ≤ Comparative setting value L  
 LL output : Display value ≤ Comparative setting value LL  
 ※ GO output ON when there are no HH, H, L, LL outputs

#### B(Block) Output Mode [0~t - b]

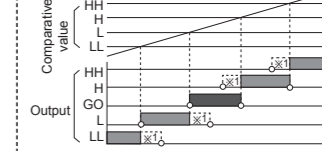

HH output : Display value ≥ Comparative setting value HH  
 H output : Display value ≥ Comparative setting value H  
 L output : Display value ≤ Comparative setting value L  
 LL output : Display value ≤ Comparative setting value LL  
 ※ GO output ON when there are no HH, H, L, LL outputs

#### I(Block) Output Mode [0~t - I]

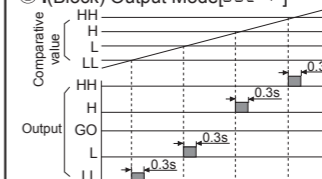

HH output : Display value ≥ Comparative setting value HH  
 H output : Display value ≥ Comparative setting value H  
 L output : Display value ≤ Comparative setting value L  
 LL output : Display value ≤ Comparative setting value LL  
 ※ No GO output  
 ※ One-shot output time is fixed at 0.3 sec.  
 ※ No hysteresis

#### F(Deflection) Output Mode [0~t - F]

Transmits outputs when the saved setting value exceeds H deviation or L deviation.

- Saving setting value: press the MODE+H keys to save as setting value.
- Checking setting value: press the H key to check the setting value.
- Setting deviation: Sets H deviation [P5t: H], and L deviation [P5t: L] of parameter group 0,2 with the setting value as reference. (The set deviation value is saved during Power OFF until it is re-set.)
- Deviation setting range: 0.0001 to 99999(the setting range varies depending on the decimal point [d: 0~t] setting).  
 E.g.) Decimal point [d: 0~t]: 0000.0, Setting range: 0.1 to 9999.9

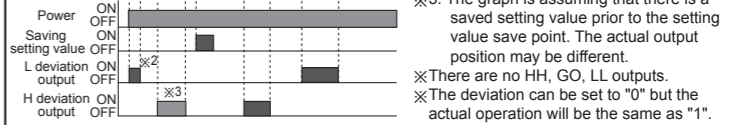

※ 2: When selecting initial comparative output limit function, it does not transmit outputs.  
 ※ 3: The graph is assuming that there is a saved setting value prior to the setting value save point. The actual output position may be different.  
 ※ There are no HH, GO, LL outputs.  
 ※ The deviation can be set to "0" but the actual operation will be the same as "1".

### Functions

#### Hysteresis [H5]

The output may turn ON/OFF frequently near the comparative setting value. To prevent this, set the hysteresis value with the comparative setting value as reference.  
 ※ A: hysteresis value  
 The hysteresis value can be set to "0



## RS485 Communication Output

• Applicable for models with RS485 communication output through sub output (MP5Y-□5, MP5W-□8/9). Please refer to 'Ordering information'.

### 1. Communication Specifications

Communication protocol	Modbus RTU	Communication Speed	2400, 4800, 9600 (default), 19200, 38400 bps
Connection method	RS485	Start Bit	1-bit fixed
Max. connections	31 units (address: 1 to 99)	Data Bit	8-bit fixed
Communication method	2-wire half duplex	Parity Bit	None (default), Even, Odd
Synchronization method	Asynchronous	Stop Bit	1, 2-bit (default)
Communication distance	Within 800m		
Communication response time	5 to 99ms (default: 20ms)		

### 2. System Configuration

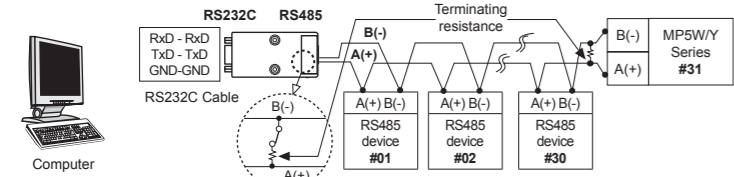

※SCM-381 (RS232C/RS485 converter, sold separately) and SCM-US481 (USB/RS485 converter, sold separately) are recommended for as communication converters. Please use twisted pair cables for RS485 communication.

### 3. Communication Control Sequence

1. Communication sequence follows Modbus RTU protocol.
2. Communication with the host system can be established after 1sec. (1,000ms) of supplying power.
3. The initial transmission authority is held by the host device (PC). When the host device transmits a request, the MP5W/Y Series sends a response.

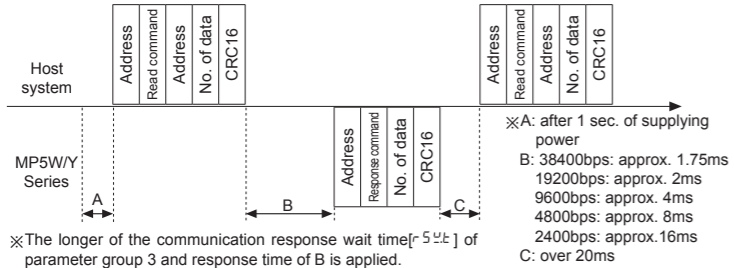

※The longer of the communication response wait time [5 sec.] of parameter group 3 and response time of B is applied.

### 4. Cautions For Communication

1. Twisted pair cable (AWG24) is recommended for RS485 communication. When not using twisted pair cables, please make sure that A (+) and B (-) cable lengths are equal.
2. After connecting the communication cable, terminating resistors (100 to 120Ω) must be attached at both ends.

### 5. Communication Command And Block Definition

#### 5-1. Read Coil Status (Func 01 H), Read Input Status (Func 02 H)

##### 1) Query (Master)

Slave Address	Function (command)	Starting Address		No. of Points(no. of data)		Error Check(CRC 16)	
		High	Low	High	Low	Low	High
1Byte	1Byte	1Byte	1Byte	1Byte	1Byte	1Byte	1Byte

##### 2) Response (Slave)

Slave Address	Function (command)	Byte Count (no. of data byte)	Data(low)		Data(high)		Error Check(CRC 16)	
			High	Low	High	Low	Low	High
1Byte	1Byte	1Byte	1Byte	1Byte	1Byte	1Byte	1Byte	

#### 5-2. Read Holding Registers(Func 03 H), Read Input Registers (Func 04 H)

##### 1) Query (Master)

Slave Address	Function (command)	Starting Address		No. of Points(no. of data)		Error Check(CRC 16)	
		High	Low	High	Low	Low	High
1Byte	1Byte	1Byte	1Byte	1Byte	1Byte	1Byte	1Byte

##### 2) Response (Slave)

Slave Address	Function (command)	Byte Count (no. of data byte)	Data		Data		Error Check(CRC 16)	
			High	Low	High	Low	Low	High
1Byte	1Byte	1Byte	1Byte	1Byte	1Byte	1Byte	1Byte	

#### 5-3. Force Single Coil (Func 05 H)

##### 1) Query (Master)

Slave Address	Function (command)	Coil Address		Force Data		Error Check(CRC 16)	
		High	Low	High	Low	Low	High
1Byte	1Byte	1Byte	1Byte	1Byte	1Byte	1Byte	1Byte

##### 2) Response (Slave)

Slave Address (address)	Function (command)	Coil Address		Force Data		Error Check(CRC 16)	
		High	Low	High	Low	Low	High
1Byte	1Byte	1Byte	1Byte	1Byte	1Byte	1Byte	1Byte

#### 5-4. Preset Single Register (Func 06 H)

##### 1) Query (Master)

Slave Address	Function (command)	Register Address		Preset Data		Error Check(CRC 16)	
		High	Low	High	Low	Low	High
1Byte	1Byte	1Byte	1Byte	1Byte	1Byte	1Byte	1Byte

##### 2) Response (Slave)

Slave Address	Function (command)	Register Address		Preset Data		Error Check(CRC 16)	
		High	Low	High	Low	Low	High
1Byte	1Byte	1Byte	1Byte	1Byte	1Byte	1Byte	1Byte

#### 5-5. Preset Multiple Registers (Func 10 H)

##### 1) Query (Master)

Slave Address	Function (command)	Starting Address		No. of Register		Byte Count	Data		Data		Error Check (CRC 16)	
		High	Low	High	Low		High	Low	High	Low	High	
1Byte	1Byte	1Byte	1Byte	1Byte	1Byte	1Byte	1Byte	1Byte	1Byte	1Byte	1Byte	1Byte

##### 2) Response (Slave)

Slave Address	Function (command)	Starting Address		No. of Register		Error Check(CRC 16)	
		High	Low	High	Low	Low	High
1Byte	1Byte	1Byte	1Byte	1Byte	1Byte	1Byte	1Byte

#### 5-6. Exception Response-Error Code(exception processing)

Slave Address	Function (command) +80H	Exception code	Error Check(CRC 16)	
			Low	High
1Byte	1Byte	1Byte	1Byte	1Byte

• When a communication error occurs, the highest bit from the received command (function) is set (1), a response command is sent, and the corresponding exception code is transmitted.

- (1) ILLEGAL FUNCTION(Exception Code: 01 H): Unsupported command
- (2) ILLEGAL DATA ADDRESS(Exception Code: 02 H): The requested start address does not match the transmission address of the device.
- (3) ILLEGAL DATA VALUE(Exception Code: 03 H): The number of requested data does not match the transmission number of the device.
- (4) SLAVE DEVICE FAILURE(Exception Code: 04 H): The requested command cannot be processed properly.(CRC)

### 6. Address Mapping Table

#### 6-1. Read Coil Status(Func 01) / Force Single Coil(Func 05)

No.(Address)	Func	R/W	Parameter	Description	Setting range	Note
000001(0000)	01	R/W	HH	HH comparative output	0: OFF / 1: ON	Comparative output LED
000002(0001)	01	R/W	H	H comparative output	0: OFF / 1: ON	
000003(0002)	01	R/W	GO	GO comparative output	0: OFF / 1: ON	
000004(0003)	01	R/W	L	L comparative output	0: OFF / 1: ON	
000005(0004)	01	R/W	LL	LL comparative output	0: OFF / 1: ON	
000006(0005)	01	R/W			0: OFF / 1: ON	
000007(0006)	01	R/W			0: OFF / 1: ON	
000008 to 000050	01	R/W			0: OFF / 1: ON	

#### 6-2. Read Input Status(Func 02)

No.(Address)	Func	R/W	Parameter	Description	Setting range	Note
100001(0000)	02	R	RESET(HOLD)	External input variables	RESET input status	
100002(0001)	02	R	BANK	BANK input status	BANK input status	
100003(0002)	02	R			0: OFF / 1: ON	
100004(0003)	02	R			0: OFF / 1: ON	
100005(0004)	02	R			0: OFF / 1: ON	
100006(0005)	02	R			0: OFF / 1: ON	
100007(0006)	02	R			0: OFF / 1: ON	
100008(0007)	02	R			0: OFF / 1: ON	
100009(0008)	02	R			0: OFF / 1: ON	
100010(0009)	02	R			0: OFF / 1: ON	
100011(000A)	02	R			0: OFF / 1: ON	
100012 to 100050	02	R			0: OFF / 1: ON	

#### 6-3. Read Input Registers(Func 04)

No.(Address)	Func	R/W	Parameter	Description	Factory default	Note
300001 to 300100	04	R		Reserved		
300101(0064)	04	R		Product number H	0	Dedicated model number
300102(0065)	04	R		Product number L	0	
300103(0066)	04	R		Hardware version	1	
300104(0067)	04	R		Software version	1	
300105(0068)	04	R		Model 1	"MP"	MP5Y-□5, MP5W-□8 (※MP5W-□9 displayed as MP5W-□8)
300106(0069)	04	R		Model 2	"S"	
300107(006A)	04	R		Model 3	"□"	
300108(006B)	04	R		Model 4	"□"	
300109(006C)	04	R		Model 5	"□"	
300110(006D)	04	R		Model 6	"□"	
300111(006E)	04	R		Model 7	"□"	
300112(006F)	04	R		Model 8	"□"	
300113(0070)	04	R		Model 9	"□"	
300114(0071)	04	R		Model 10	"□"	
300115(0072)	04	R		Reserved		
300116(0073)	04	R		Reserved		
300117(0074)	04	R		Reserved		
300118(0075)	04	R		Coil status start address	0000	
300119(0076)	04	R		Coil status quantity	0	
300120(0077)	04	R		Input status start address	0000	
300121(0078)	04	R		Input status quantity	0	
300122(0079)	04	R		Holding register start address	0000	
300123(007A)	04	R		Holding register quantity	0	
300124(007B)	04	R		Input register start address	0000	
300125(007C)	04	R		Input register quantity	0	
300126 to 300200	04	R		Reserved		

No.(Address)	Func	R/W	Parameter	Description	Setting range	Factory default
301001(03E8)	04	R	HH H GO L LL	HH LED Display H LED Display GO LED Display L LED Display LL LED Display	0: OFF / 1: ON 0: OFF / 1: ON 0: OFF / 1: ON 0: OFF / 1: ON 0: OFF / 1: ON	0-bit 1-bit 2-bit 3-bit 4-bit
301002(03E9)	04	R	PV	Measurement value	-19999 to 99999	
301003(03EA)	04	R			0: 00000 3: 00000 1: 00000 4: 00000 2: 00000	
301004(03EB)	04	R	DOT		0: 999.99s 5: 999.99m 1: 9999.9s 6: 9999.9m 2: 99m 59.9s 7: 99h 59.9m 3: 9h 59m 59s 8: 99h 59m 4: 99999s 9: 99999m	
301005(03EC)	04	R	UNIT			
301006(03ED)	04	R	MODE	Operation mode	0: F1 to 1: F2 14: F15 2: F3 15: F16	
301007(03EE)	04	R				

#### 6-4. Read Holding Registers(Func 03) / Preset Single Register(Func 06)

##### Preset Multiple Registers(Func 16)

##### 6-4-1. Comparative value settings and peak value check group

No.(Address)	Func	R/W	Parameter	Description	Setting range	Factory default
400001(0000)	03/16	R/W	P5t.HH	Preset HH	HH comparative value	0 to 99999
400002(0001)	03/16	R/W	P5t.H	Preset H	H comparative value	0 to 99999
400003(0002)	03/16	R/W	P5t.L	Preset L	L comparative value	0 to 99999*1
400004(0003)	03/16	R/W	P5t.LL	Preset LL	LL comparative value	0 to 99999*1
400005(0004)	03/16	R/W	P5t.LL	Preset LL	LL comparative value	0 to 99999*1
400006(0005)	03/16	R/W	P5t.LL	Preset LL	LL comparative value	0 to 99999*1
400007(0006)	03/16	R/W	P5t.LL	Preset LL	LL comparative value	0 to 99999*1
400008(0007)	03/16	R/W	P5t.LL	Preset LL	LL comparative value	0 to 99999*1
400009(0008)	03/16	R/W	HPEL	High peak	High peak value of measured value	99999*2
400010(0009)	03/16	R/W	HPEL	High peak	High peak value of measured value	99999*2
400011(000A)	03/16	R/W	LPEL	Low peak	Low peak value of measured value	-19999*2
400012(000B)	03/16	R/W	LPEL	Low peak	Low peak value of measured value	-19999*2
400013 to 400050	03/16	R/W		Reserved		

\*1: In operation modes F8, F10, F14, F15, the setting range is -19999 to 99999

\*2: Max./Min. measurement value

##### 6-4-2. Parameter 1 Group

No.(Address)	Func	R/W	Parameter	Description	Setting range	Factory default
400051(0032)	03/16	R/W	n o d E	Mode	Input operation mode	0: F1 to 1: F2 15: F16
400052(0033)	03/16	R/W	i n - A	Input A	Sensor type	0: n P n H F 1: n P n L F 2: P n P H F 3: P n P L F
400053(0034)	03/16	R/W	i n - B	Input B	Sensor type	0: 5 t A r - d 1: o U t - H 2: o U t - L 3: o U t - b 4: o U t - i 5: o U t - F
400054(0035)	03/16	R/W	o U t - t	Output type	Output mode	0
400055(0036)	03/16	R/W	H y S	Hysteresis	Hysteresis value	1 to 9999
400056(0037)	03/16	R/W	G U A r - d	Output limit	Output limit function	0: F d E F y 1: S t A r - t
400057(0038)	03/16	R/W	S t A r - t	Start limit value	Start compensation timer value	0.0 to 99.9
400058(0039)	03/16	R/W	A U t - z e r o A	Auto-zero A	Auto-zero time	0.1 to 9999.9
400059(003A)	03/16	R/W	A U t - z e r o B	Auto-zero B	Auto-zero time	9999.9
400060(003B)	03/16	R/W	A U t - z e r o B	Auto-zero B	Auto-zero time	9999.9
400061(003C)	03/16	R/W	A U t - z e r o B	Auto-zero B	Auto-zero time	9999.9
400062(003D)	03/16	R/W	n e n o	Memory	Memory retention	0: o F F 1: o n
400063 to 400100	03/16	R/W		Reserved		

##### 6-4-3. Parameter 2 Group

No.(Address)	Func	R/W	Parameter	Description	Setting range	Factory default
--------------	------	-----	-----------	-------------	---------------	-----------------