

3 1/2 DIGITAL DOUBLE OPEN JAW AC CLAMP MULTIMETER OPERATION MANUAL

1. SAFETY INFORMATION

The following safety information must be observed to insure maximum personal safety during the operation at this meter.

1.1 Do not operate the meter if the body of meter or the test lead look broken.

1.2 Check the main function dial and make sure it is at the correct position before each measurement.

1.3 Do not perform resistance test on a live power system.

1.4 Do not apply voltage between the test terminals and test terminal to ground that exceed the maximum limit record in this manual.

1.5 Exercise extreme caution when measuring live system with voltage greater than 60V DC or 30V AC.

1.6 Change the battery when the "E" symbol appears to avoid incorrect data.

2. Panel Layout

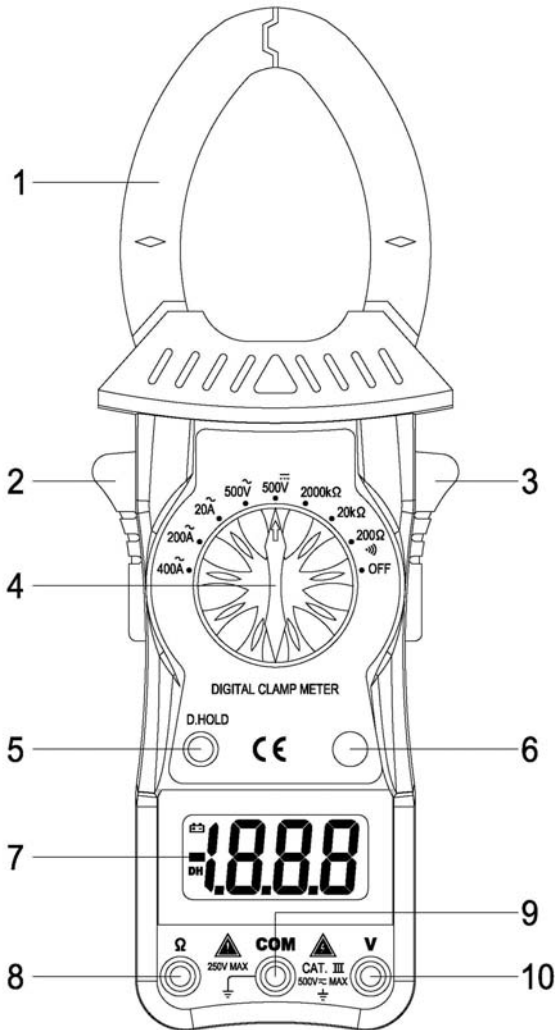

- (1) Clamp jaws: Opens 38mm to enclose conductor.
 (2), (3) Jaw-opening handle: Opens and closes the jaws.
 (4) Rotary Switch: use this switch to select functions and ranges.
 (5) D.HOLD key: In any range, push the key, the present display value will be locked and the "DH" symbol will appear, push it again to exit HOLD and the "DH" symbol disappear.

(6) CDS sensor: The CDS sensor can reaction to the ambient brightness range, then automatically control the LCD backlight to lighten or go out.

(7) LCD Display

(8) Ω Input Jack.

(9) COM Input Jack.

(10) V Input Jack.

3. SPECIFICATIONS

3.1 GENERAL SPECIFICATIONS

Display: 3 1/2 digit LCD with a max. reading of 1999.

Polarity: Automatic negative polarity indication.

Zero adjustment: Automatic.

Over-range indication: Only the "1" or "-1" display.

Low battery indication: "E"

Safety Standards: The meter is up to the standards of IEC1010 Double Insulation, Pollution Degree 2, Over-voltage Category III.

Data hold: Push the D.HOLD key and the DH sign will appear on the display.

Clamp opening size: 38mm.

Operating Environment:

Temperature 32~104°F (0~40°C), humidity<80%RH.

Storage Environment:

Temperature -4~140°F (-20~60°C), humidity<90%RH.

Power supply: 3×1.5V AAA batteries.

Dimension: 193(H)×73(W)×26(D)mm.

Weight: Approx. 325g (including battery).

3.2 ELECTRICAL SPECIFICATIONS

Accuracies are \pm (% of reading + number in last digit) at 23 \pm 5°C, \leq 75%RH.

3.2.1 DC Voltage

Range	Accuracy	Resolution
500V	0.8% of rdg + 2 digits	1V

Overload protection: 500V DC / 500V rms AC

Impedance: 10M Ω

3.2.2 AC Voltage

Range	Accuracy	Resolution
500V	1.2% of rdg + 3 digits	1V

Average sensing, calibrated to rms of sine wave

Frequency: 40~400Hz

Overload protection: 500V DC / 500V rms AC

Impedance: 10M Ω

3.2.3 AC Current

Range	Accuracy	Resolution
20A	2.0% of rdg + 5 digits	10mA
200A		0.1A
400A	2.5% of rdg + 5 digits	1A

Average sensing, calibrated to rms of sine wave

Frequency: 50~60Hz

Overload protection: AC 400A within 60 seconds

3.2.4 Resistance

Range	Accuracy	Resolution
200Ω	1.5% of rdg + 5 digits	0.1Ω
20kΩ	1.0% of rdg + 5 digits	10Ω
2000kΩ	1.5% of rdg + 5 digits	1kΩ

Overload protection: 250V DC / 250V rms AC

3.2.5 Diode test and Audible continuity test

Range	Description	Test condition
·)	Built-in buzzer sounds if resistance is less than 50Ω	Open circuit voltage approx. 3V

Overload protection: 250V DC / 250V rms AC

4. OPERATION

4.1 DC Voltage Measurement

- 1) Connect the black test lead to "COM" socket and red test lead to the "V" socket.
- 2) Set the selector switch to "500 V $\overline{\text{—}}$ " position.
- 3) Measure the voltage by touch the test lead tips to the test circuit where the value of voltage is needed.
- 4) Read the result from the LCD panel. The polarity of the red lead connection will be indicated along with the voltage value.

4.2 AC Voltage Measurement

- 1) Connect the black test lead to "COM" socket and red test lead to the "V" socket.
- 2) Set the selector switch to "500V \sim " position.
- 3) Measure the voltage by touch the test lead tips to the test circuit where the value of voltage is needed.
- 4) Read the result from the LCD panel.

4.3 AC Current Measurement

- 1) Set the selector switch to desired "20A \sim ", "200A \sim " or "400A \sim " position.
- 2) Open the clamp by pressing the jaw-opening handle and insert the cable to be measured into the jaw.
- 3) Close the clamp and get the reading from the LCD panel.

Note:

- A) Before this measurement, disconnect the test lead with the meter for safety.
- B) If the current range is not known before hand, set the selector switch to high range and work down.

4.4 Resistance Measurement

- 1) Connect the black test lead to "COM" socket and red test lead to the "Ω" socket.
- 2) Set the selector switch to "200Ω $\cdot|)$ ", "20kΩ" or "2000kΩ" position.
- 3) Connect tip of the test leads to the points where the value of the resistance is needed.
- 4) Read the result from the LCD panel.

Note:

When take resistance value from a circuit system, make sure the

power is cut off and all capacitors need to be discharged.

4.5 Audible continuity Test

- 1) Connect the black test lead to "COM" socket and red test lead to the "Ω" socket.
- 2) Set the selector switch to desired "200Ω $\cdot|)$ " position.
- 3) Connect the test leads to two point of circuit, if the resistance is lower than approx. 50Ω, the buzzer sounds.

Note:

When take resistance value from a circuit system, make sure the power is cut off and all capacitors need to be discharged.

5. Battery replacement

- 1) When the battery voltage drop below proper operation range the "E $\overline{\text{—}}$ " symbol will appear on the LCD display and the battery need to changed.
- 2) Before changing the battery, set the selector switch to "OFF" position. Open the cover of the battery cabinet by a screwdriver.
- 3) Replace the old battery with the same type battery (AAA 1.5V \times 3).
- 4) Close the bottom case and fasten the screw.

6. MAINTENANCE

- 1) Before open the bottom case, disconnect both test lead and never uses the meter before the bottom case is closed.
- 2) To avoid contamination or static damage, do not touch the circuit board without proper static protection.
- 3) If the meter is not going to be used for a long time, take out the battery and do not store the meter in high temperature or high humidity environment.
- 4) When take current measurement, keep the cable at the center of the clamp will get more accurate test result.
- 5) Repairs or servicing not covered in this manual should only by qualified personal.
- 6) Periodically wipe the case with a dry cloth and detergent. Do not use abrasives or solvents on this instruments.
- 7) Please take out the battery when not using for a long time.

Above picture and content just for your reference. Please be subject to the actual products if anything different or updated. Please pardon for not informing in advance.