

*50 MHz to 3 GHz Radio Frequency Radiation Meters  
Electromagnetic Field strength measurement*

# 3 AXIS RF ELECTROMAGNETIC FIELD METER

Model : EMF-819



Your purchase of this RF EMF METER marks a step forward for you into the field of precision measurement. Although this METER is a complex and delicate instrument, its durable structure will allow many years of use if proper operating techniques are developed. Please read the following instructions carefully and always keep this manual within easy reach.



## OPERATION MANUAL

# TABLE OF CONTENTS

1. FEATURES.....	1
2. APPLICATIONS.....	2
3. SAFETY INSTRUCTIONS.....	2
4. SPECIFICATIONS.....	4
5. FRONT PANEL DESCRIPTION.....	6
6. MEASUREMENT CONSIDERATION.....	7
7. MEASURING PROCEDURE.....	8
7-1 Buttons instructions.....	8
7-2 Symbols & units of display.....	9
7-3 Unit Selection.....	10
7-4 Frequency Team Selection.....	10
7-5 Alarm Limit Setting and Alarm start.....	10
7-6 Data Hold.....	11
7-7 Data Record (Max., Min. reading).....	11
7-8 Peak Hold.....	12
8. AUTO POWER DISABLE.....	12
9. RS232 PC SERIAL INTERFACE.....	12
10. BATTERY REPLACEMENT.....	14
11. SYSTEM RESET.....	14
12. OPTIONAL ACCESSORIES.....	15

# 1. FEATURES

- \* 3 Axis probe.
- \* Radio frequency electromagnetic field tester.
- \* Wide measuring frequency ranges, 50 MHz to 3 GHz.
- \* EMF-819 is used for broadband devices of monitoring the wide range radio frequency electromagnetic field value.
- \* For precision measurement consideration, the meter is included one probe :  
EP-05H ( Frequency range : 50 MHz to 3 GHz )
- \* Unit : V/m, W/m<sup>2</sup>, mW/cm<sup>2</sup>.
- \* Frequency Selection, two points : Normal, 2.45 GHz.
- \* Alarm setting function can warn the user if the measuring antenna is too near the strong radiation sources, the buzzer will sound to remind the user.
- \* Peak hold function to latch peak value.
- \* Data hold function to lock the current reading.
- \* RS232 computer interface.
- \* Hard carrying case is included..
- \* Large size LCD with contrast adjustment, which can fit best viewing angle.
- \* Microcomputer circuit provides special function & offers high accuracy.
- \* Powered by 006P DC 9V battery or DC 9V adapter.

## 2. APPLICATIONS

This meter is specially developed for measuring or monitoring electromagnetic field, for example: cell-phone station, hospital equipment, radar , micro-wave oven, radiation work, TV antenna , Radio station , welding equipment , baking- equipment, television , computer , factory, laboratory , and other environment...etc.

## 3. SAFETY INSTRUCTIONS

### ***Danger***

- \* For worker's safety, be aware that persons with electromagnetic implant ( e.g. cardiac-pacemaker ) are subject to especial danger in some case.
- \* Particular to observe the local safety regulations of the operator of the equipment.
- \* Before using the device, it need to know that how to setting " alarm-limit " value ( refer to page 10 ).

### ***Attention***

- \* Claims by some scientists that long term exposure to electromagnetic field may be the cause of childhood leukemia & other forms of cancer.
- \* Complete answers to any of these and related questions are not currently available. At the present time the most common practice is to avoid excess exposure over long period of time.

- \* Complete answers to any of these and related " Prudent Avoidance " as stated by the Environmental Protection Agency(EPA) USA is recommended.
- \* According to ICNIRP of reference levels to time-varying electromagnetic fields. The E-field strength levels are:

**General public**

<b>Frequency range</b>	<b>e-field strength (V/m)</b>
10 to 400 MHz	28
400 to 2000 MHz	$1.375 \times f^{1/2}$
2 to 300 GHz	61

**Occupational**

<b>Frequency range</b>	<b>e-field strength (V/m)</b>
10 to 400 MHz	61
400 to 2000 MHz	$3 \times f^{1/2}$
2 to 300 GHz	137

## 4. SPECIFICATIONS

### 4-1 General Specifications

Circuit	Custom one-chip of microprocessor LSI circuit.
Display	LCD size : 58 mm x 34 mm.
Measurement Unit	V/m, mW/cm <sup>2</sup> , W/m <sup>2</sup> .
Accuracy	< 2 dB.
Probe structure	3 Axis.
Probe Input Impedance	50 OHM
Frequency Selection	Two points selection : Normal, 2.45 GHz.
Sensor Structure	Semiconductor
Data Hold	Freeze the display reading.
REC Function	Record Maximum & Minimum value.
Power off	Auto shut off saves battery life or manual off by push button. <i>* Can default auto power off or manual power off.</i> <i>* When default auto power off , power will off automatically after 10 min. if no button be pressed.</i>
Peak Hold	To latch the peak measurement value.
Alarm Setting	Buzzer will sound when display over the setting value.
Sampling Time	Approx. 1 second.
Low Battery Indicator	When display show Low battery Indicator, it should change the batteries.
Data Output	RS 232 PC serial interface.
Operating Temperature	0 to 50 °C.
Operating Humidity	Less than 80 %RH.

Power Supply	DC 9 V battery ( 006P ) * <i>Heavy duty or Alkaline type.</i>
	DC 9V adapter input.
Power Current	Approx. DC 5.95 mA
Weight	425 g/ 0.94 LB.
Dimension	<i>Main instrument :</i> 200.0 x 76.2 x 36.8 mm <i>Probe :</i> 70 mm ( diameter) x 240 mm ( length)
Accessories Included	Instruction manual..... 1 PC EP-05H Probe..... 1 PC Memory card for EP-05H..... 1 PC Hard carrying case, CA-06..... 1 PC
Optional Accessories	RS232 cable, UPCB-02. USB cable, USB-01. Data Acquisition software, SW-U801-WIN.

#### **4-2 Electrical Specifications ( 23 ± 5 °C )**

<b>Strength Range</b>	<b>Resolution</b>	<b>Effective Value</b>
0 to 200.00 V/m	0.01 V/m	> 1 V/m
0 to 99.999 W/m <sup>2</sup>	0.001 W/m <sup>2</sup>	> 0.03 W/m <sup>2</sup>
0 to 9.9999 mW/cm <sup>2</sup>	0.0001 mW/cm <sup>2</sup>	> 0.0003 mW/cm <sup>2</sup>

<b>Frequency Range</b>	<b>Accuracy</b>	<b>Test Point</b>
50 MHz to 3.0 GHz *	< 2 dB *	60 V/m

**Remark:**

- \* *The above accuracy is specified base on the measurement frequency within 100 MHz to 2.5 GHz.*
- \* *Measurement under other frequency range ( below 100 MHz and over 2.5 GHz ), the reading value just for reference only.*
- \* *For precision measurement consideration, it should select the " Frequency Team point " to the convenient points ( normal or 2.45 GHz ).*

## 5. FRONT PANEL DESCRIPTION

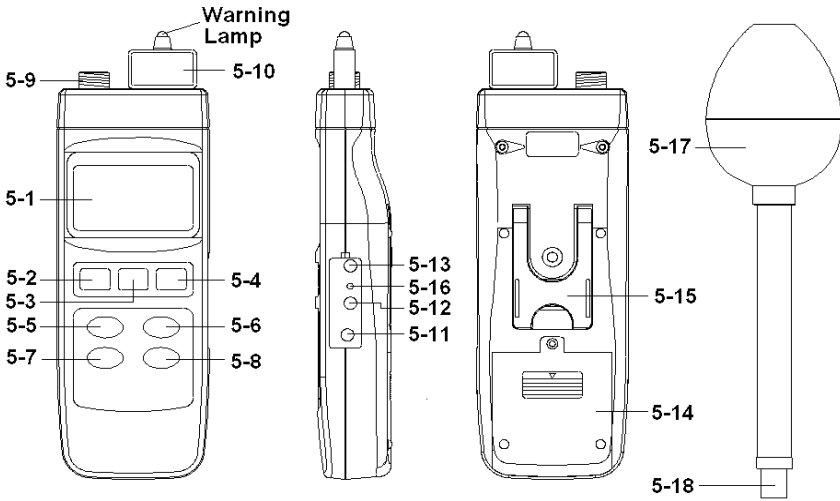

Fig. 1

5-1 Display  
5-2 Power Button  
5-3 Hold / ESC Button  
5-4 REC / Enter Button  
5-5 Freq. Team Button  
5-6 Unit Button  
5-7 Peak Hold Button  
5-8 Alarm Set / Start Button  
5-9 Probe Input Socket

5-10 Probe Memory Card  
5-11 DC Adapter Input Socket  
5-12 RS-232 Output Terminal  
5-13 LCD contrast adj.  
5-14 Battery Cover  
5-15 Stand  
5-16 Reset Button  
5-17 Probe Sensing Head  
5-18 Probe Plug



## 6. MEASUREMENT CONSIDERATION

- 1) Connect the " Probe Plug " ( 5-18, Fig. 1 ) into the " Probe Input Socket " ( 5-9, Fig. 1 ).
- 2) Plug in the exclusive " Probe Memory Card " ( 5-10, Fig. 1 ) into the front end socket of meter.

***Remark :***

- \* ***Probe memory card is saved the Probe's character into the internal memory circuit.***
  - \* ***Each probe should cooperate its own exclusive " Probe Memory card ", do not plug the another card, otherwise the accuracy will exist certain deviation.***
- \* If intend to make the measurement precisely.  
Make sure to use the " Frequency Team Button " ( 5-5, Fig. 1 ) ) to select the convenient point that according the measurement object.

***Consideration :***

- \* ***There are two frequency selection points : Normal, 2.45 GHz.***
- \* ***The default selection is " Normal ", however if the measurement frequency is microwave or its frequency is near " 2.45 GHz ", it should select to " 2.45 GHz " will get the high precision.***

3) The meter is built in the 3 axis ( X, Y, Z ) EMF sensors, the circuit measures each X, Y, Z sensor's EMF value, then the CPU will calculate the total EMF value according to the following formula :

$$\sqrt{X^2 + Y^2 + Z^2}$$

*X : The EMF value that sensing from the X direction.*

*Y : The EMF value that sensing from the Y direction.*

*Z : The EMF value that sensing from the Z direction.*

## 7. MEASURING PROCEDURE

### 7 -1 Buttons instructions

<b>Buttons</b>	<b>Function</b>
Power Button	Press this key to power on or off.
Hold Button	Press this key to freeze the reading value.
ESC Button	When operate " SET " functions, press this key to escape..
REC Button	Press this key to record maximum or minimum value.
Enter Button	When operate " SET " functions, press this key to enter value.
Freq. Team Button	Press this key to select the convenient object's frequency value. Two points selection : Normal, 2.45 GHz.
Unit Button	Press this key to select V/m,W/m <sup>2</sup> , mW/cm <sup>2</sup> of strength units.
Peak Hold Button	Press this key to latch peak value during the measurement.
Alarm Set /Start Button	Press this key to setting alarm high/low limit or start alarm function.

## 7 -2 Symbols & units of display

<b><i>Symbol &amp; Unit</i></b>	<b><i>Function</i></b>
V/m	Electric field strength
W/m <sup>2</sup>	Power density
mW/cm <sup>2</sup>	Power density
Normal, 2.45 GHz	Frequency team indicates.
PEAK HOLD	Appears on the " PEAK HOLD " function. It will latch the peak value.
REC	Appears on the " REC " function, it will record maximum and minimum value.
HOLD	Appears on the " HOLD " function, it will freeze the present reading.
Alarm setting low limit	Appear on the " Alarm setting Low limit " function.
Alarm setting High limit	Appears on the "Alarm setting High limit" function.
Alarm setting hysteresis	Appears on the "Alarm setting hysteresis " function.
Flash unit on the display	Appears on the " START " function, it indicate the ALARM FUNCTION has starting.

### ***7-3 Unit Selection***

After inserting the " Probe Memory Card " ( 5-10, Fig. 1 ) and connecting " Probe Plug " ( 5-18, Fig. 1 ) into the " Probe Input Socket " ( 5-9, Fig. 1 ), use " Unit Button " ( 5-6, Fig. 1 ) to select the " V/m, W/m<sup>2</sup>, mW/cm<sup>2</sup> ".

### ***7-4 Frequency Teams Selection***

- 1) Use the " Freq. Team Button " ( 5-5, Fig. 1 ) to select the proper frequency team.
- 2) The default selection is " Normal ", however if the measurement frequency is microwave or its frequency is near " 2.45 GHz ", it should select to " 2.45 GHz " to get the high precision.
- 3) If user don't know the exact information, just select to the " Normal ".

### ***7-5 Alarm limit setting and Alarm start***

- 1) Press the "Alarm Button " ( 5-8, Fig. 1 ) once to start the alarm function, while the " units " symbol will flash on the display.
- 2) Press the " Alarm Button " ( 5-8, Fig. 1 ) once again to stop the alarm function.
- 3) Press the " Alarm Button " ( 5-8, Fig. 1 ) continuously and over 2 seconds, the "Alarm low limit value " will indicate on the lower display, use the " ▼, ▲ Buttons " to adjust the desiring low limit value.
- 4) Press the " Enter Button " ( 5-4, Fig. 1 ) will save the low limit value and going to adjust the " High limit value, procedures will similar as above.

- 5) After finish the " High limit value " adjustment, press the " Enter Button " ( 5-4, Fig. 1 ) will save the high limit value and going to adjust the alarm Hysteresis value, procedures will similar as above. Upon finish the alarm " Hysteresis value " adjustment, press the " Enter Button " ( 5-4, Fig. 1 ) will save the data.
- 6) Press the " ESC Button " ( 5-3, Fig. 1 ) to finish alarm setting procedures.

### **7-6 Data hold**

During the measurement, press the " Hold Button " ( 5-3, Fig. 1 ) once will hold the measured value & the LCD will indicate a " HOLD " symbol.

Press the " Hold Button " once again will release the data hold function.

### **7-7 Data Record ( Max., Min. reading )**

- \* The data record function records the maximum and minimum readings. Press the " REC Button " ( 5-4, Fig. 1 ) once to start the Data Record function and it will be a " REC " symbol on the display.
- \* When the " REC " symbol on the display :
  - a) Press the " REC Button " ( 5-4, Fig. 1 ) once, the " REC MAX " symbol along with the maximum value will appear on the display. Press the " REC Button " ( 5-4, Fig. 1 ) once again, the " REC MIN " symbol along with the minimum value. If intend to delete the maximum ( Minimum ) value, just press the " Hold Button " ( 5-3, Fig. 1 ) once, then the display will show the " REC " symbol only & execute the memory function continuously.
  - b) To exit the memory record function, just press the " REC Button " ( 5-4, Fig. 1 ) 2 seconds continuously at least. The display will revert to the current reading.

**7-8 Peak Hold**

Press the " Peak Hold Button " ( 5-7, Fig. 1 ) once to latch peak value on the display , press once again to exit the peak hold function.

**8. AUTO POWER OFF DISABLE**

The instrument has built-in "Auto Power Shut-off" in order to prolong battery life. The meter will switch off automatically if none of the buttons are pressed within 10 min.

To de-activate this feature, Select the memory record function during measurement, by pressing the " RECORD " button ( 5-4, Fig. 1 ).

**9. RS232 PC SERIAL INTERFACE**

The instrument has RS232 PC serial interface via a 3.5 mm terminal ( 5-12, Fig. 1 ).

The data output is a 16 digit stream which can be utilized for user's specific application.

A RS232 lead with the following connection will be required to link the instrument with the PC serial port.

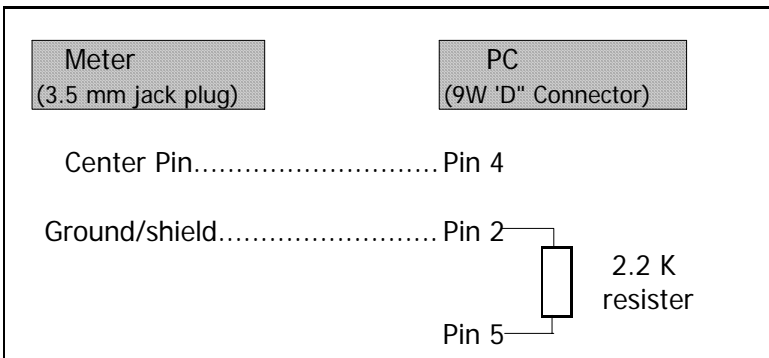

The 16 digits data stream will be displayed in the following format :

D15 D14 D13 D12 D11 D10 D9 D8 D7 D6 D5 D4 D3 D2 D1 D0

**Each digit indicates the following status :**

D0	End Word = 0D
D1 & D8	Display reading, D1 = LSD, D8 = MSD For example : If the display reading is 1234, then D8 to D1 is : 00001234
D9	Decimal Point(DP), position from right to the left 0 = No DP, 1= 1 DP, 2 = 2 DP, 3 = 3 DP
D10	Polarity 0 = Positive 1 = Negative
D11 & D12	Annunciator for Display W/m <sup>2</sup> =A9   mW/cm <sup>2</sup> = A8   V/m = A7
D13	When send the upper display data = 1 When send the lower display data = 2
D14	4
D15	Start Word = 02

**RS232 setting**

Baud rate	9600
Parity	No parity
Data bit no.	8 Data bits
Stop bit	1 Stop bit

## 10. BATTERY REPLACEMENT

When the left corner of LCD display show "  ", it is necessary to replace the batteries ( 006P ).

- 1) Slide the " Battery Cover " ( 5-14, Fig. 1 ) away from the instrument and remove the battery.
- 2) Replace with batteries ( 006P ) and reinstate the cover.
- 3) Make sure the battery cover is secured after changing the battery.

## 11. SYSTEM RESET

If the meter happen the troubles such as :

*CPU system is garbled ( for example, the key button can not be operated..... ).*

Then make the system RESET will fix the problem.  
The system RESET procedures will be either following method :

**During the Power On, used a pin tool to push the " System Reset " button ( 5-16, Fig. 1 ) once.**



## 12. OPTIONAL ACCESSORIES

RS232 cable UPCB-02	* Computer interface cable. * Used to connect the meter to the computer ( COM port ).
USB cable USB-01	* Computer interface cable. * Used to connect the meter to the computer ( USB port ).
Data Acquisition software SW-U801WIN	* The SW-U801-WIN is a multi displays ( 1/2/4/6/8 displays ) powerful application software, provides the functions of data logging system, text display, angular display, chart display, data recorder high/low limit, data query, text report, chart report.. .xxx.mdb data file can be retrieved for EXCEL, ACCESS., wide intelligent applications.